

*Live in a safe and durable timber house*



**ALUMINIUM FOUNDATION SYSTEM FOR LIGHTWEIGHT AND TIMBER BUILDINGS**

*Alufoot is a patent and a registred trademark belonging to the University of Padova*



System patented by the University of Padua (PCT/ IB2012/056544) - Trademark registered.

Experts are aware that the critical and until now unsolved problem of timber buildings lies in proper anchoring of the structure to its foundations. Traditional techniques - reinforced concrete curbs and/or larch base beams - have several disadvantages, examples being excessive geometric inaccuracies, difficulty in achieving efficient and long-lasting fixings, compression orthogonal to the wood grain, reduced durability due to rising damp, problems with proper waterproofing and thermal insulation of foundations, etc. Inadequate solutions for the foundation node lead to a shorter lifespan and reduced structural performance of the entire building. Difficulties and delays during the installation of timber buildings, due to geometric errors in the foundations, are commonplace.

ALUFOOT® is an innovative foundation system for lightweight timber buildings, constructed with Cross-Lam or light timber frame technologies, solving all the above problems.

The ALUFOOT® base beams are made of an extruded aluminum profile. Shape and size are optimized for maximum bearing capacity. Special grooves on the sides of the profile allow fast, efficient anchoring of timber walls by means of special plates and hold-downs.

The ease of installation of ALUFOOT® profiles ensures worksite efficiency and cleanliness. Accessories are designed for extremely accurate leveling of base beams, both in plan and in elevation. This means that the assembly is easier and faster, greatly reducing costs and time.

The ALUFOOT® base beams prevent damp rising to the timber walls. Special rubber bands ensure proper contact between walls and profiles, providing the required airtightness. The thermal conductivity of the profiles is comparable to that of concrete curbs.

The ALUFOOT® beam system can provide a safe and durable wooden house lasting forever and saving costs and time of installation!

## ALUFOOT® SYSTEM FEATURES

- Aluminum foundation beams, lightweight and infinitely durable
- Beams substitute r.c. curbs and larch base beams
- Beams allow perfect horizontal and vertical alignment of foundation plan
- Easy, efficient fastening of timber walls
- No drilling or fastening to r.c. base beams
- Certified load capacity of aluminum base beams
- Certified load capacity anchoring plates and holddowns
- Thermal bridging reduced at wall bases
- No rising damp from wall bases
- Easy waterproofing and thermal insulation of foundations
- Durability and natural healthiness of timber construction
- Savings in costs, due to speed of construction



**XLam**



**Platform Frame**



**Blockbau**



**Recovery**

**HIGH Series  
Classic Line**

**New ALUBEAM 100**

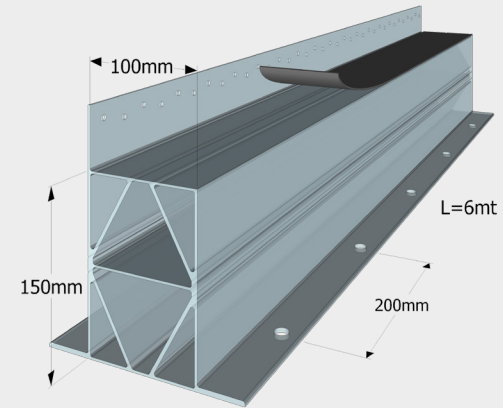

**New ALUBEAM 120**

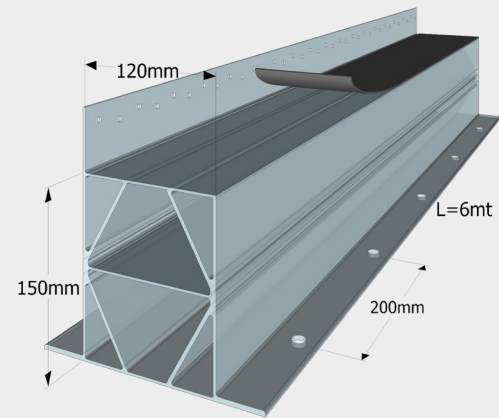

**LOW Series  
L Line**

**ALUBEAM 100L**

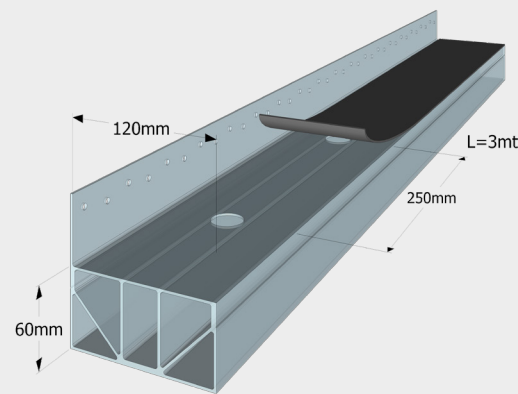

**ALUBEAM 120L**

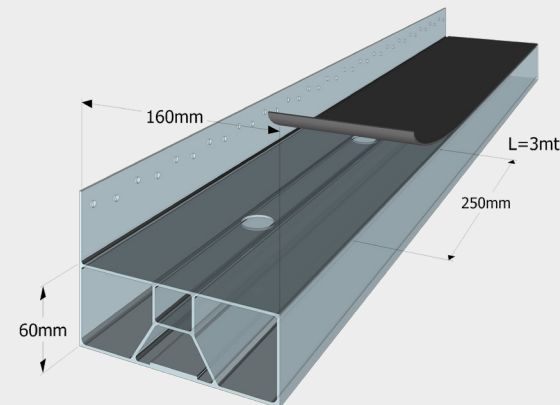

**ALUBEAM 160L**

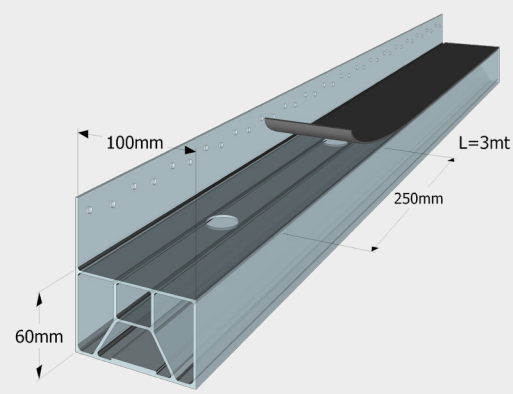

**ACCESORIES**

**RUBBER 100**

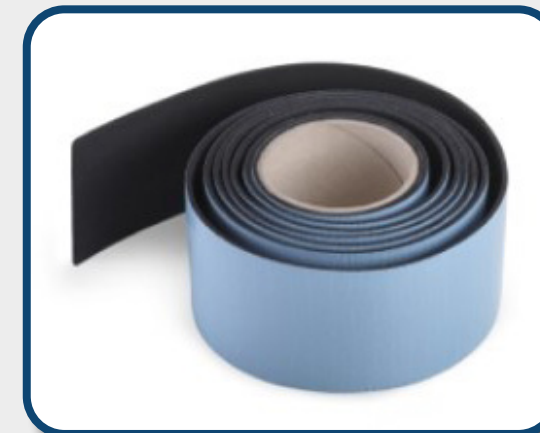

95 mm adhesive EPDM rubber

**RUBBER 120**

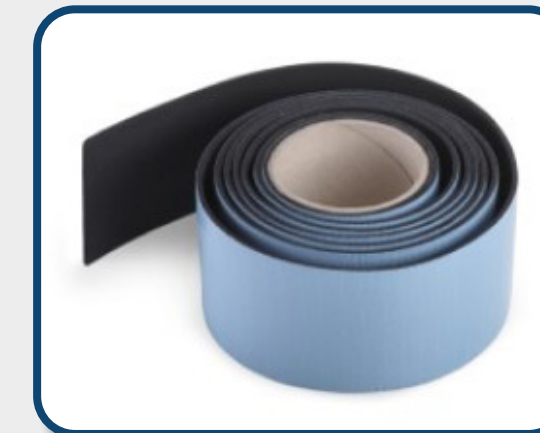

115 mm adhesive EPDM rubber

**RUBBER 160**



160 mm adhesive EPDM rubber

## NEW ALUBEAM 100

for the construction of a residential home



## NEW ALUBEAM 160L

for the construction of a school campus



## Our team

Our team of experts is available to provide technical support assistance for new installation designs of our aluminum system, as well as for repair of wooden buildings.



## Our services

- Project evaluation
- Technical - economic offer
- Cutting list development
- Construction development



## Our mission

WAT srl provides the more suitable solutions to builders and professional customers.

Contact us.





**ALUFOOT**®

ALUMINIUM INNOVATIONS FOR TIMBER BUILDINGS

AN INVESTMENT FOR THE FUTURE

## SOCIAL

 375 6292151

 @alufot

 alufot

## CONTACTS

### WAT srl

Via Terraglio, 14 - 31022 Preganziol - TV  
C.F. - P.IVA: 04069220244  
Tel. +39 0422 1784956  
Mob. +39 375 6292151  
[info@alufot.com](mailto:info@alufot.com)  
[www.alufot.com](http://www.alufot.com)

